

# Status Light Quick Reference

Many of the components of the FRC Control System have indicator lights that can be used to quickly diagnose problems with your robot. This guide shows each of the hardware components and describes the meaning of the indicators. Photos and information from Innovation FIRST and Cross the Road Electronics.

## Robot Signal Light (RSL)

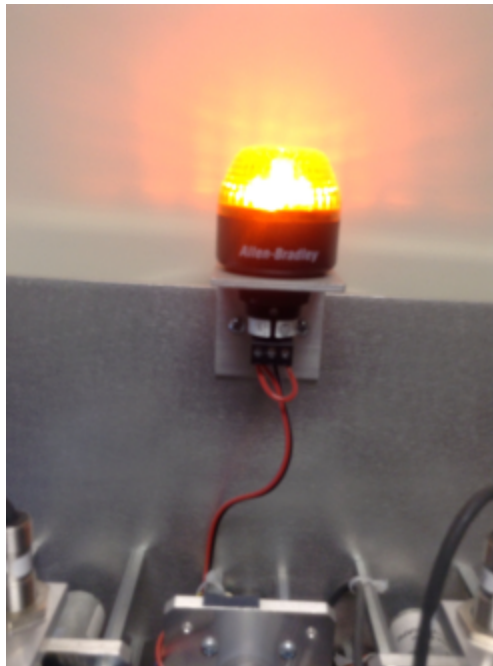

- Solid ON - Robot On and Disabled
- Blinking - Robot On and Enabled
- Off - Robot Off, roboRIO not powered or RSL not wired properly.

## RoboRIO

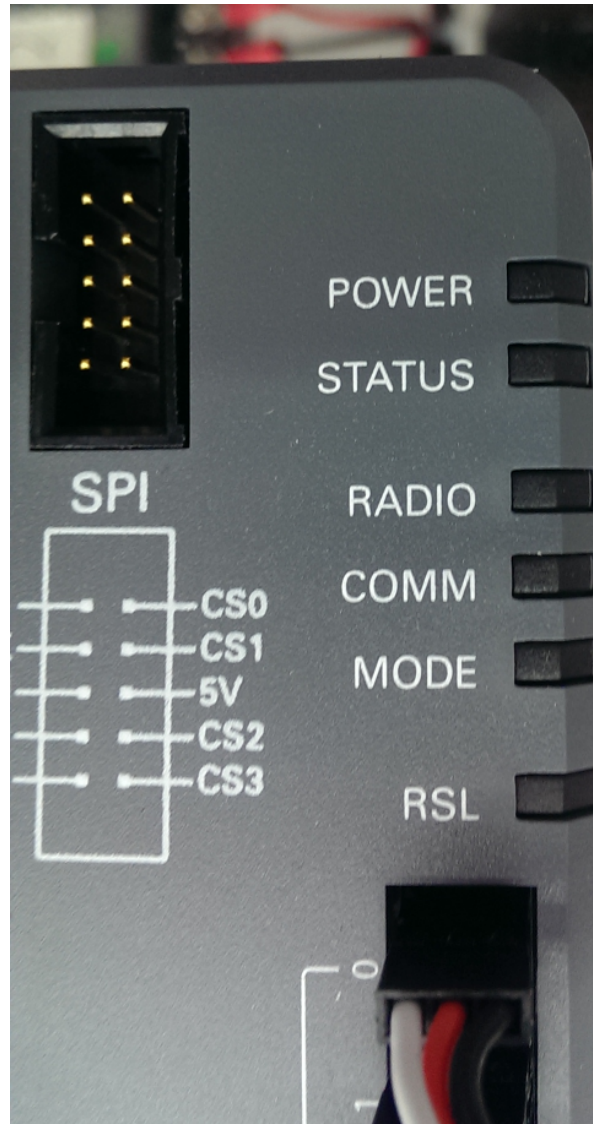

### Power

- Green - Power is good
- Amber - Brownout protection tripped, outputs disabled
- Red - Power fault, check user rails for short circuit

### Status

- On while the controller is booting, then should turn off
- 2 blinks - Software error, reimage roboRIO
- 3 blinks - Safe Mode, restart roboRIO, reimage if not resolved
- 4 blinks - Software crashed twice without rebooting, reboot roboRIO, reimage if not resolved
- Constant flash or stays solid on - Unrecoverable error

## **Radio**

Not currently implemented

## **Comm**

- Off - No Communication
- Red Solid - Communication with DS, but no user code
- Red Blinking - E-stop
- Green Solid - Good communication with DS

## **Mode**

- Off - Outputs disabled (robot in Disabled, brown-out, etc.)
- Amber/Orange - Autonomous Enabled
- Green - Teleop Enabled
- Red - Test Enabled

## **RSL**

See above

## Power Distribution Panel



### LED Fault Table

LED	Strobe	Slow	Long
Green	No Fault - Robot Enabled	No Fault - Robot Disabled	NA
Orange	NA	Sticky Fault	NA
Red	NA	No CAN Comm	NA

\*If PCM LED contains more than one color, see LED Special States Table

### LED Special States Table

LED Colors	Problem
Red/ Orange	Damaged Hardware
Green/ Orange	In Bootloader
No LED	No Power / Incorrect Polarity

## Voltage Regulator Module

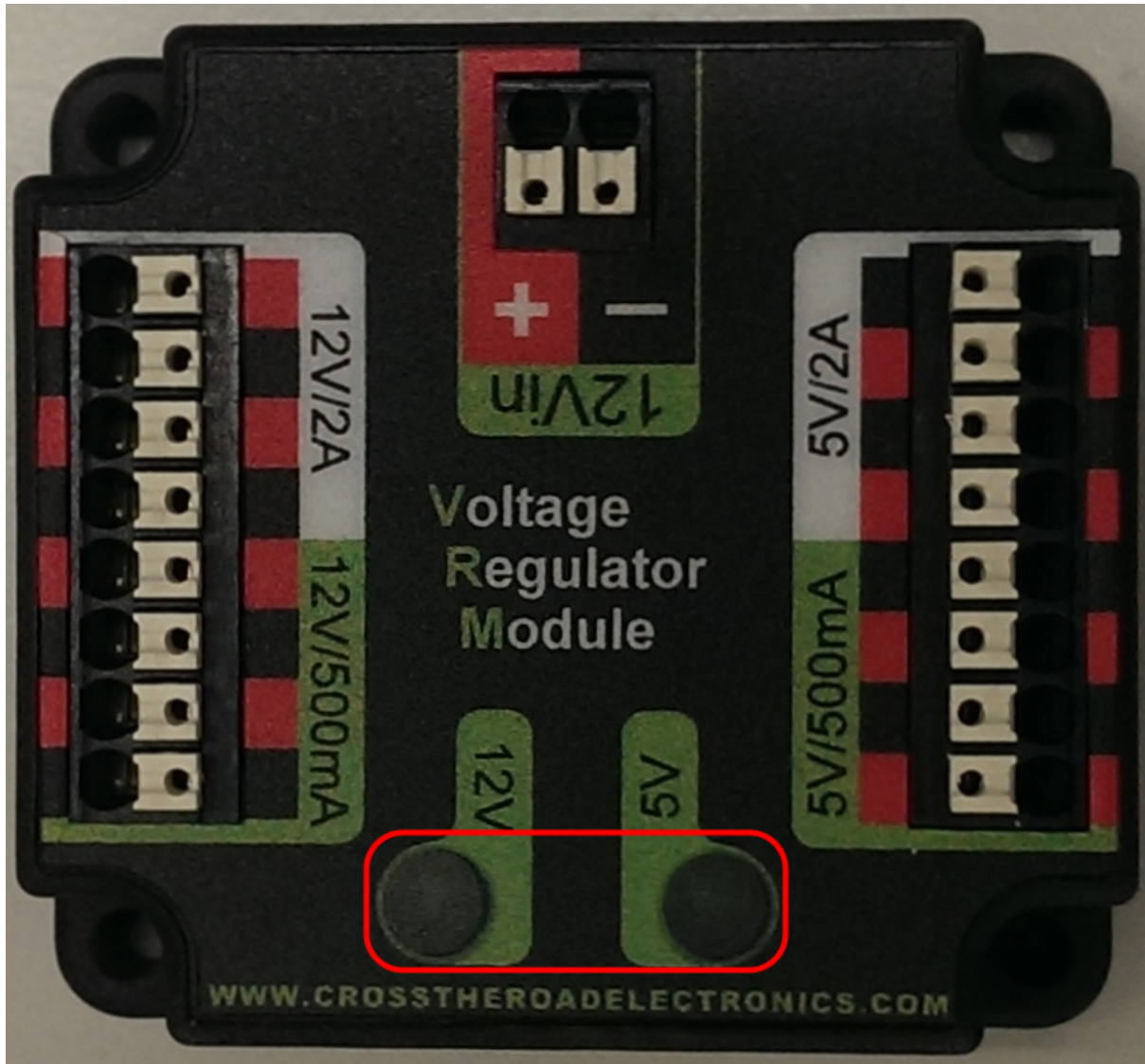

The status LEDs on the VRM indicate the state of the two power supplies. If the supply is functioning properly the LED should be lit bright green. If the LED is not lit or is dim, the output may be shorted or drawing too much current.

## Pneumatics Control Module

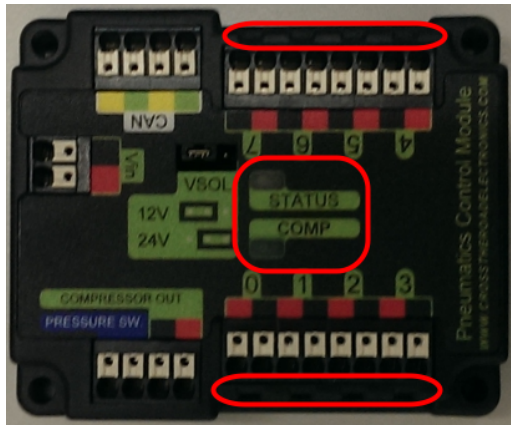

**LED Fault Table**

LED	Strobe	Slow	Long
Green	No Fault - Robot Enabled	No Fault - Robot Disabled	NA
Orange	NA	Sticky Fault	NA
Red	NA	No CAN Comm OR Solenoid Fault (Blinks Solenoid Index)	Compressor Fault

\*If PCM LED contains more than one color, see LED Special States Table

**LED Special States Table**

LED Colors	Problem
Red/ Orange	Damaged Hardware
Green/ Orange	In Bootloader
No LED	No Power / Incorrect Polarity

**Solenoid Channel LEDs** - These LEDs are lit red if the Solenoid channel is enabled and not lit if it is disabled.

**Comp** - This is the Compressor LED. This LED is green when the compressor output is active (compressor is currently on) and off when the compressor output is not active.

**Status** - The status LED indicates device status as indicated by the two tables above. For more information on resolving PCM faults see the PCM User Manual. Note that the No CAN Comm fault will

not occur only if the device cannot see communicate with any other device, if the PCM and PDP can communicate with each other, but not the roboRIO you will NOT see a No Can Comm fault.

## Jaguar speed controllers



LED State	Module Status
Normal Operating Conditions	
Solid Yellow	Neutral (speed set to 0)
Fast Flashing Green	Forward
Fast Flashing Red	Reverse
Solid Green	Full-speed forward
Solid Red	Full-speed reverse
Fault Conditions	
Slow Flashing Yellow	Loss of servo or Network link
Fast Flashing Yellow	Invalid CAN ID
Slow Flashing Red	Voltage, Temperature, or Limit Switch fault condition
Slow Flashing Red and Yellow	Current fault condition

LED State	Module Status
Calibration Conditions	
Fast Flashing Red and Green	Calibration mode active
Fast Flashing Red and Yellow	Calibration mode failure
Slow Flashing Green and Yellow	Calibration mode success
Slow Flashing Red and Green	Calibration mode reset to factory default settings success
Other Conditions	
Slow Flashing Green	Waiting in CAN Assignment mode

## Talon speed controllers

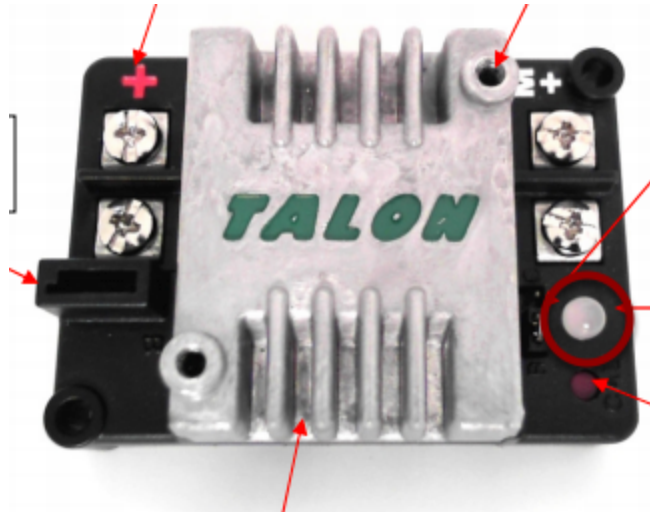

The LED is used to indicate the direction and percentage of throttle and state of calibration. The LED may be one of three colors; red, orange or green. A solid green LED indicates positive output voltage equal to the input voltage of the Talon. A solid Red LED indicates an output voltage that is equal to the input voltage multiplied by -1(input voltage = 12 volts, output equals -12 volts). The LED will blink it's corresponding color for any throttle less than 100% (red indicates negative polarity, green indicates positive). The rate at which the led blinks is proportional to the percent throttle. The faster the LED blinks the closer the output is to 100% in either polarity.

The LED will blink orange any time the Talon is in the disabled state. This will happen if the PWM input signal is lost, or in FRC, when the robot is disabled. If the Talon is in the enabled state and the throttle is within the 4% dead band, the LED will remain solid orange.

Flashing Red/Green indicate ready for calibration. Several green flashes indicates successful calibration, and red several times indicates unsuccessful calibration.

## Victor speed controllers



LED Indicator Status:

**Green** - full forward

**Orange** - neutral / brake

**Red** - full reverse

**Flashing orange** - no PWM signal

**Flashing red/green** - calibration mode

**Flashing green** - successful calibration

**Flashing red** - unsuccessful calibration

## Victor-SP speed controllers

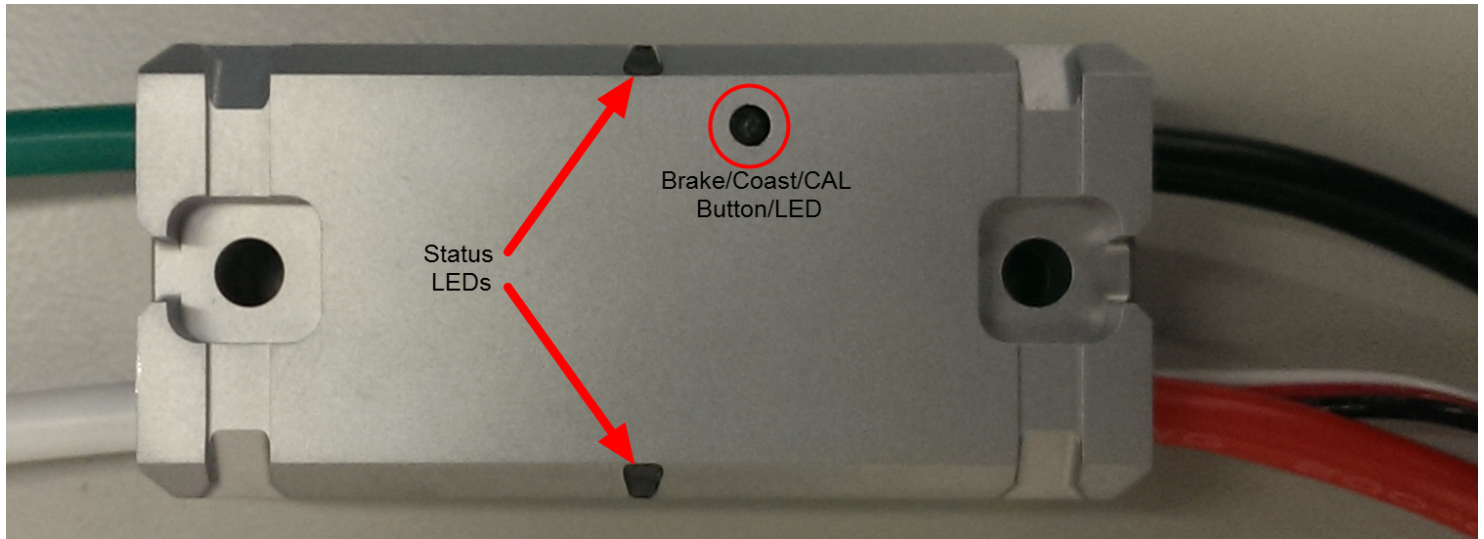

Brake/Coast/Cal Button/LED - Red if the controller is in brake mode, off if the controller is in coast mode

### Status

The Status LEDs are used to indicate the direction and percentage of throttle and state of calibration. The LEDs may be one of three colors; red, orange or green. Solid green LEDs indicate positive output voltage equal to the input voltage of the Victor-SP. Solid Red LEDs indicate an output voltage that is equal to the input voltage multiplied by -1(input voltage = 12 volts, output equals -12 volts). The LEDs will blink in the corresponding color for any throttle less than 100% (red indicates negative polarity, green indicates positive). The rate at which the LEDs blink is proportional to the percent throttle. The faster the LEDs blink the closer the output is to 100% in either polarity.

The LEDs will blink orange any time the Victor-SP is in the disabled state. This will happen if the PWM input signal is lost, or in FRC, when the robot is disabled. If the Victor-SP is in the enabled state and the throttle is within the 4% dead band, the LED will remain solid orange.

Flashing Red/Green indicate ready for calibration. Several green flashes indicates successful calibration, and red several times indicates unsuccessful calibration.

## Talon-SRX speed controllers

Blink Codes During Calibration	
Status LEDs Blink Code	Talon SRX State
Flashing Red/Green	Calibration Mode
Blinking Green	Successful Calibration
Blinking Red	Failed Calibration

Blink Codes During Normal Operation		
LEDs	Colors	Talon SRX State
Both	Blinking Green	Forward throttle is applied. Blink rate is proportional to Duty Cycle
Both	Blinking Red	Reverse throttle is applied. Blink rate is proportional to Duty Cycle
None	None	No Power is being applied to Talon SRX
LEDs Alternate <sup>1</sup>	Off/Orange	CAN bus detected, robot disabled
LEDs Alternate <sup>1</sup>	Off/Slow Red	CAN bus/PWM is not detected
LEDs Alternate <sup>1</sup>	Off/Fast Red	Fault Detected
LEDs Alternate <sup>1</sup>	Red/Orange	Damaged Hardware
LEDs Strobe "towards" (M+) <sup>2</sup>	Off/Red	Forward Limit Switch or Forward Soft Limit
LEDs Strobe "towards" (M-) <sup>2</sup>	Off/Red	Reverse Limit Switch or Reverse Soft Limit
LED1 Only "closest" to M+/V+	Green/Orange	In Boot-loader

B/C CAL Blink Codes	
B/C CAL Button Color	Talon SRX State
Solid Red	Brake Mode
Off	Coast Mode

## Spike relay configured as a motor, light, or solenoid switch

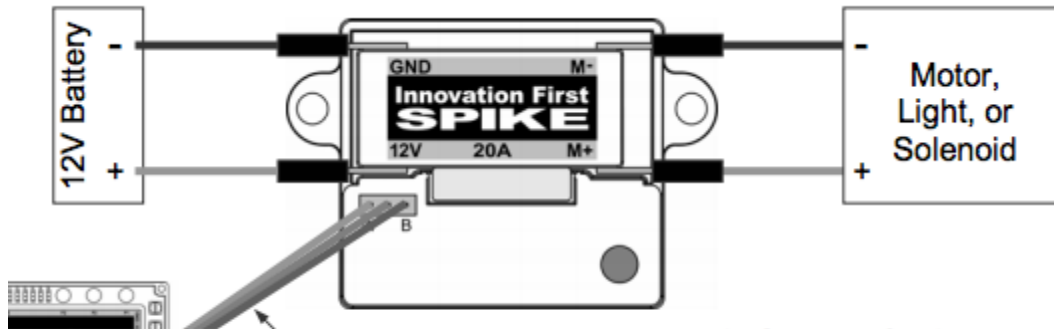

INPUTS		OUTPUTS		Indicator	Motor Function
Fwd(Wh)	Rev(Red)	M+	M-		
0	0	GND	GND	Orange	OFF / Brake Condition (default)
1	0	+12v	GND	Green	Motor rotates in one direction
0	1	GND	+12v	Red	Motor rotates in opposite direction
1	1	+12v	+12v	Off	OFF / Brake Condition

**Notes:**

1. 'Brake' refers to the dynamic stopping of the motor due to the shorting of the motor inputs. This condition is not optional when going to an off state.
2. The INPUT Fwd and Rev are defined as follows: 0 (Off) and 1 (On).

## Spike relay configured as for one or two solenoids

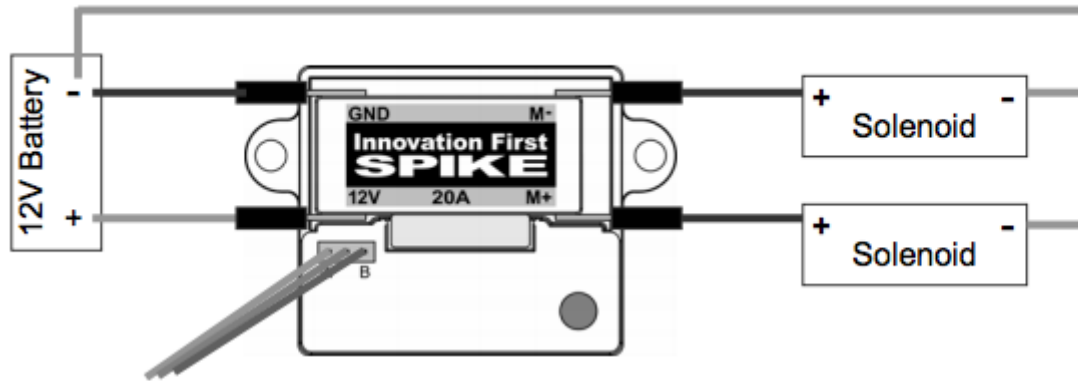

INPUT		OUTPUTS			
Fwd(Wh)	Rev(Red)	M+	M-	Indicator	Solenoid Function
0	0	GND	GND	Orange	Both Solenoids OFF (default)
1	0	+12v	GND	Green	Solenoid connected to M+ is ON
0	1	GND	+12v	Red	Solenoid connected to M- is ON
1	1	+12v	+12v	Off	Both Solenoids ON

Note:

1. The INPUT Fwd and Rev are defined as follows: 0 (Off) and 1 (On).